

FlexiAnvil™

Adjustable Anvil Roller

User Manual



Shandong HOACO Automation Technology Co., Ltd.

CONTENTS

1.Overview.....	1
2.Core Structure and Functional Features (Ease of Use and Stability).....	1
3.Core Technical Parameters (Accuracy and Basic Specifications).....	1
4.Structure and Function.....	2
5.Installation.....	3
6.Height Adjustment.....	4
7.Scale Indication And Adjustment Accuracy.....	4
8.Maintenance.....	5

Introduction to the FlexiAnvil™

1. Overview

The FlexiAnvil is a high-precision component of the rotary die cutting machine. Its design parameters and structural features directly determine its compatibility and operational stability across applications.

High-precision adjustment reduces die wear and extends service life.

High compatibility fits various machine models, meeting die-cutting requirements across industries.

Versatile use accommodates different materials and thicknesses.

The roller features a simplified exterior without external transmission components, and all internal adjustment parts are fully sealed for lifetime maintenance-free operation.

2. Core Structure and Functional Features (Ease of Use and Stability)

The FlexiAnvil is designed around three core principles: high-precision adjustment, convenient operation, and stable compatibility. This design addresses common issues of traditional adjustable anvil rollers, such as complex installation, insufficient accuracy, and drive misalignment.



2.1. High-Precision Adjustment: Built-in Reduction Mechanism

The anvil integrates a high-precision reduction mechanism inside, which amplifies adjustment accuracy through mechanical reduction. Combined with a minimum adjustment increment of 0.0005 mm, it enables micron-level height control.



2.2. Convenient Operation: Icon Indicators + Integrated Design

All functional options are clearly marked with icon indicators, allowing operators to quickly understand the operation logic without special training. The adjustment components (e.g., reduction gears, knobs) are fully built-in, preventing external interference and reducing the risk of accidental operation.



2.3. Flexible Compatibility: Same Dimensions as Standard Anvil Rollers

The FlexiAnvil matches the dimensions of standard anvil rollers (length, diameter, mounting holes). Replacement or addition requires no modification to the machine and can be installed directly, significantly reducing retrofitting costs and downtime.



2.4. Stable Transmission: Floating Connection Design

A unique floating connection keeps the gear position fixed during anvil height adjustment, maintaining the gear center distance. This prevents gear meshing deviation, reduces transmission noise and wear, and ensures long-term operational stability.

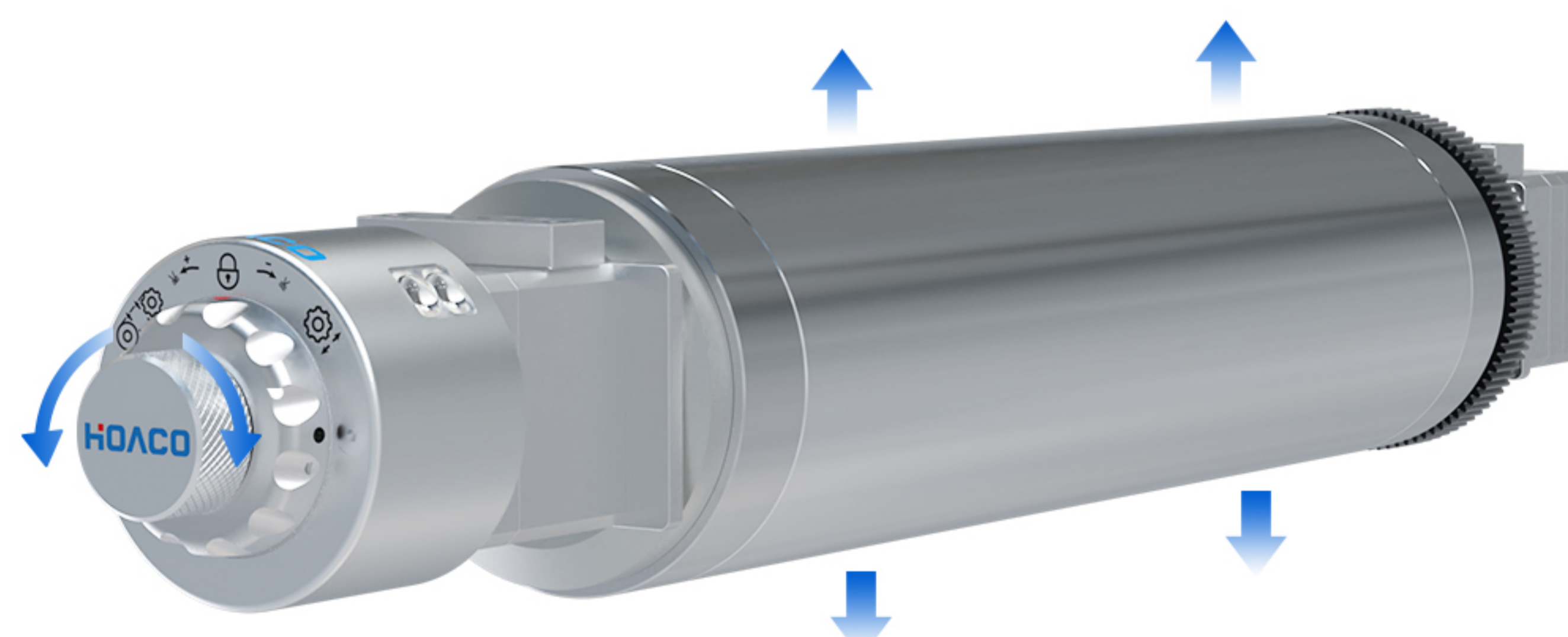

3. Core Technical Parameters (Accuracy and Basic Specifications)

Technical parameters are key indicators of the FlexiAnvil's performance, directly affecting adjustment precision, load capacity, and compatibility. The specific parameters and their significance are as follows:

Adjustment range ±0.075 mm

Vertical adjustment range: ±0.075 mm-defines the adjustable scope of the anvil. This range meets the fine spacing requirements in most precision pressing and lamination processes.

Increment 0.001 mm (1 μm)

Minimum adjustment increment: 0.001 mm – reflects the fineness of adjustment. Such a small increment enables ultra-precise control and prevents deviations in product accuracy caused by excessive adjustment.

Anvil diameter Φ81.8

Teeth Z81

Gear teeth: Z81 – a key parameter matching the machine's drive system. The Z81 design ensures a stable transmission ratio, reduces impact and noise during operation, and improves smoothness of motion.

Material

High overall hardness ensures the anvil remains deformation-free during long-term use. Chrome plating enhances wear resistance and corrosion resistance, prolongs service life, and reduces material adhesion.

Customizable

The roller dimensions and diameter can be customized according to customer's process requirements.

4. Structure and Function

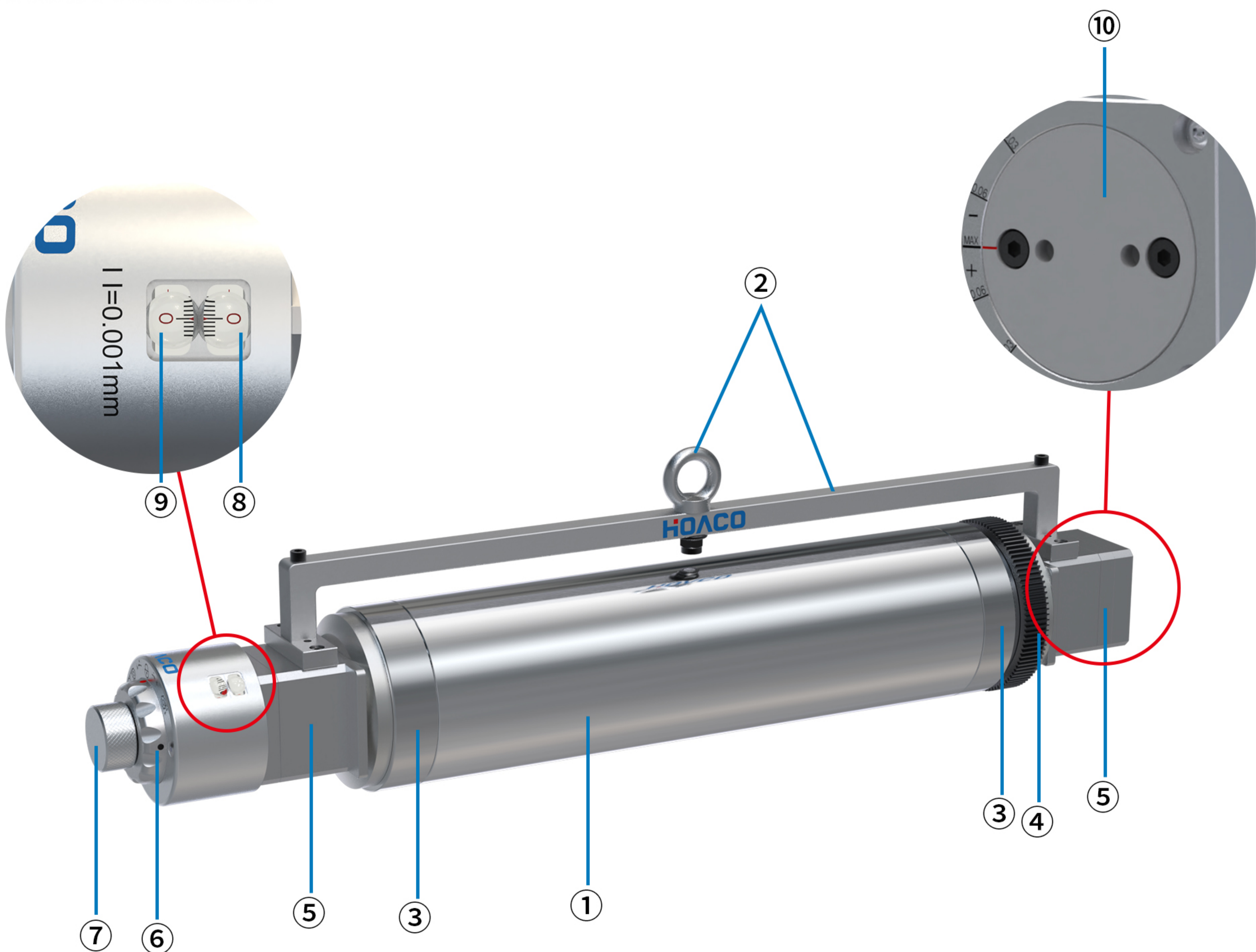

- | | | | |
|-------------------|--------------------------------|----------------|-------------------|
| ① Anvil | ② Hanger | ③ Support Ring | ④ Drive Gear |
| ⑤ Bearing block | ⑥ Selector Knob | ⑦ Height knob | ⑧ Gear-Side Scale |
| ⑨ Knob-Side Scale | ⑩ Height Limit Adjustment Dial | | |

5. Installation

- *The FlexiAnvil must be installed and removed using a crane or lifter by attaching the hook to the lifting ring on the hanger.
- *Once the FlexiAnvil is installed onto the station, remove the hanger and store it properly.
- *Before removing the FlexiAnvil from the station, reinstall the hanger first.
- *The bearing blocks on both sides must not be subjected to load.

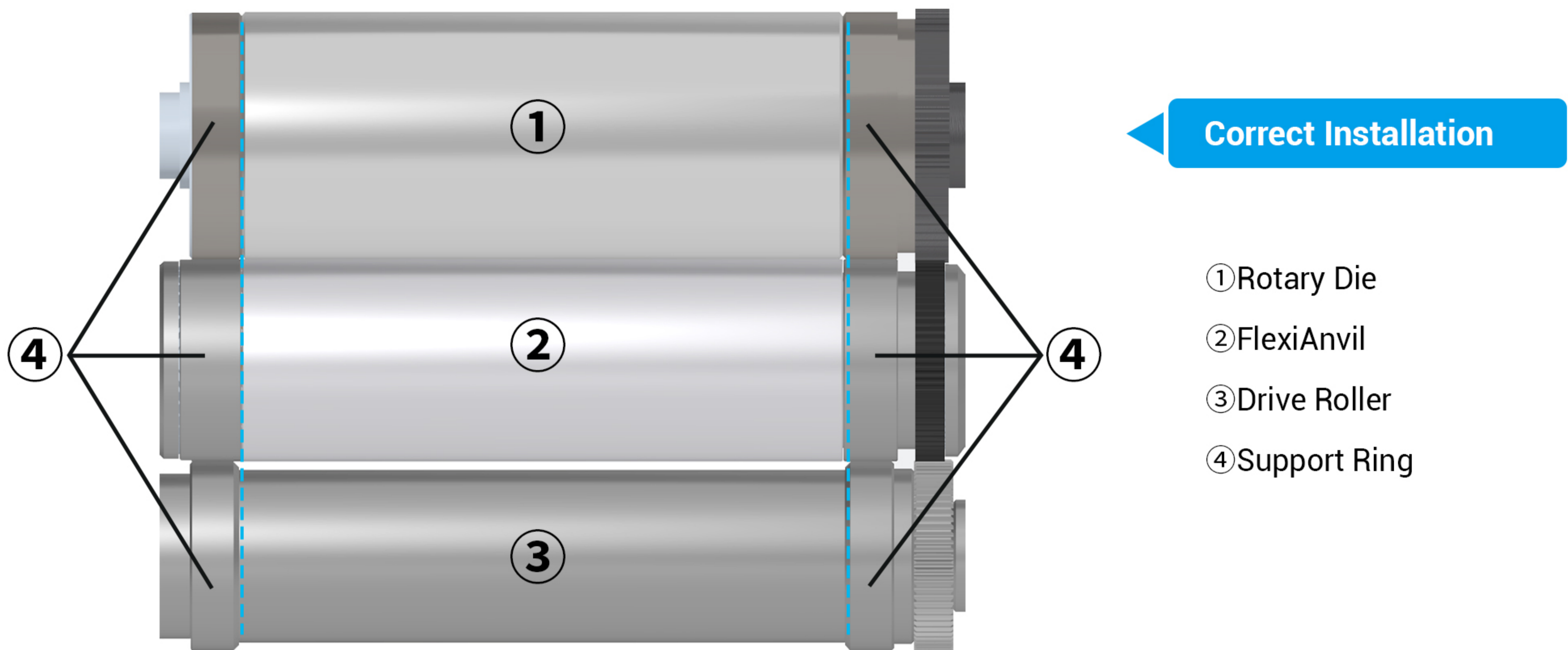

Incorrect Installation

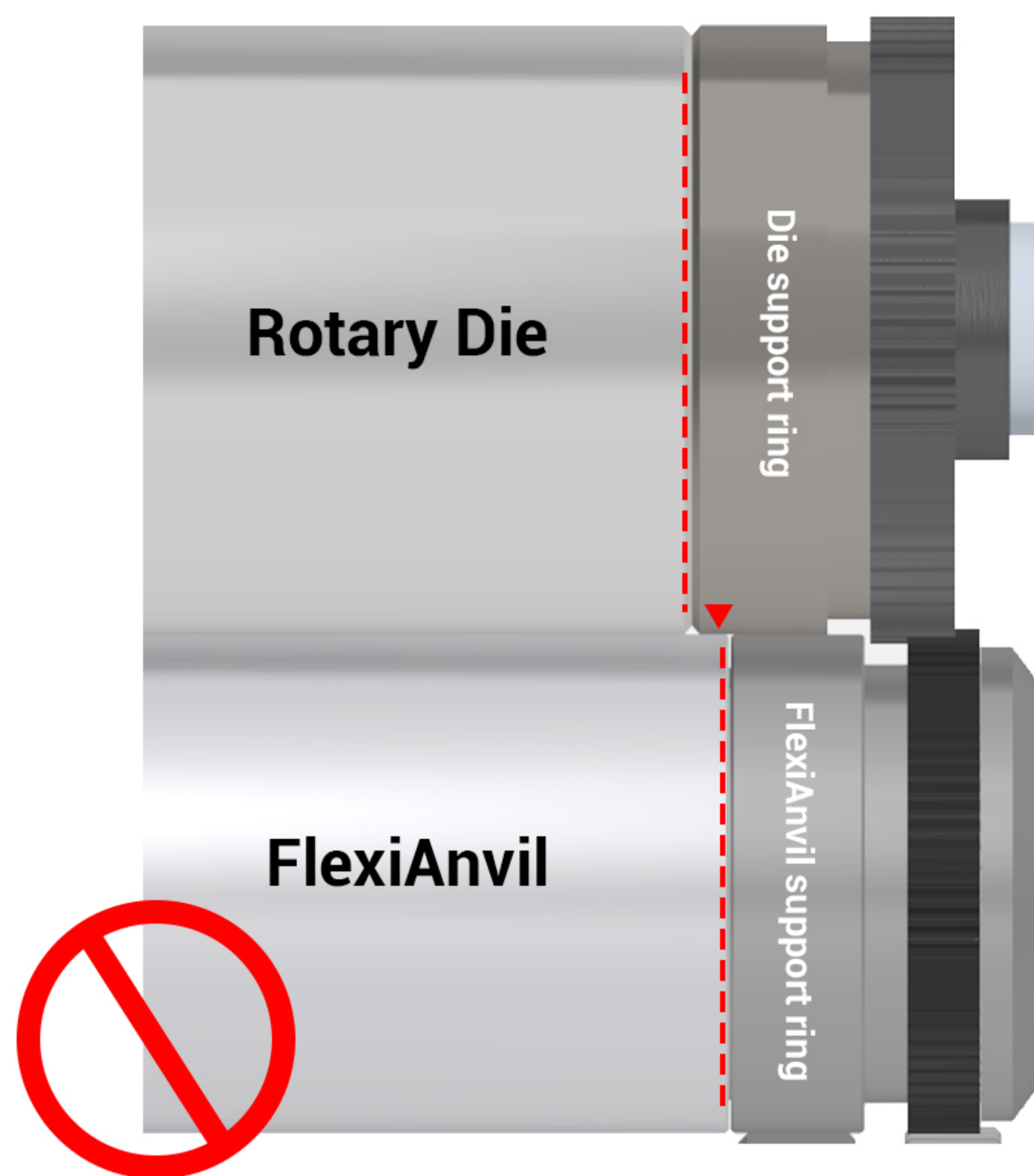

The die support ring is pressed onto the FlexiAnvil support ring

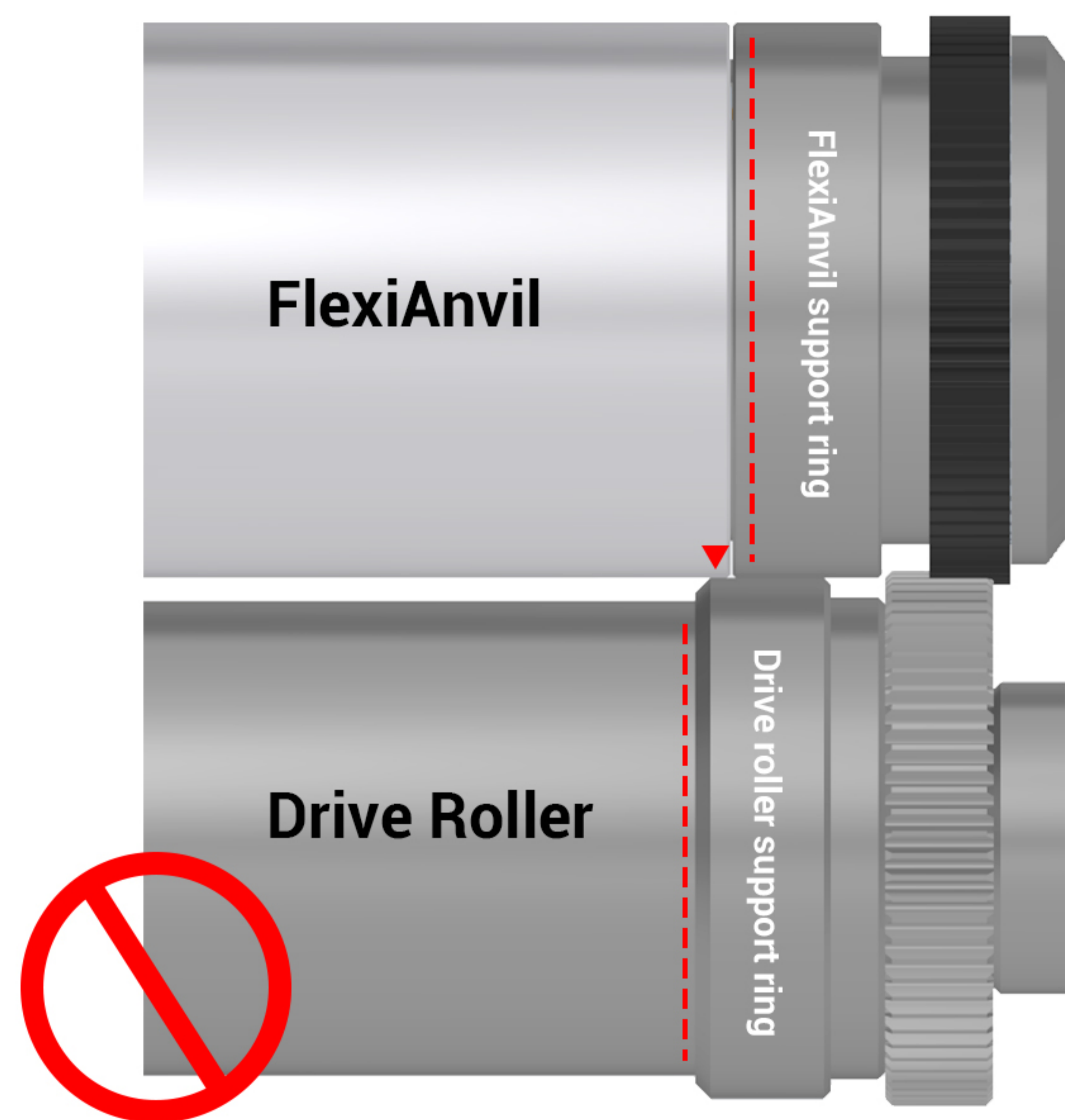

The FlexiAnvil support ring is pressed onto the drive roller support ring

To ensure precise and consistent die pressure when adjusting the anvil height during die-cutting operations, it is recommended to use a gauge-type adjustable hydraulic mechanism to apply pressure to the die. We suggest using the HOACO pressure bridge with pressure gauge.

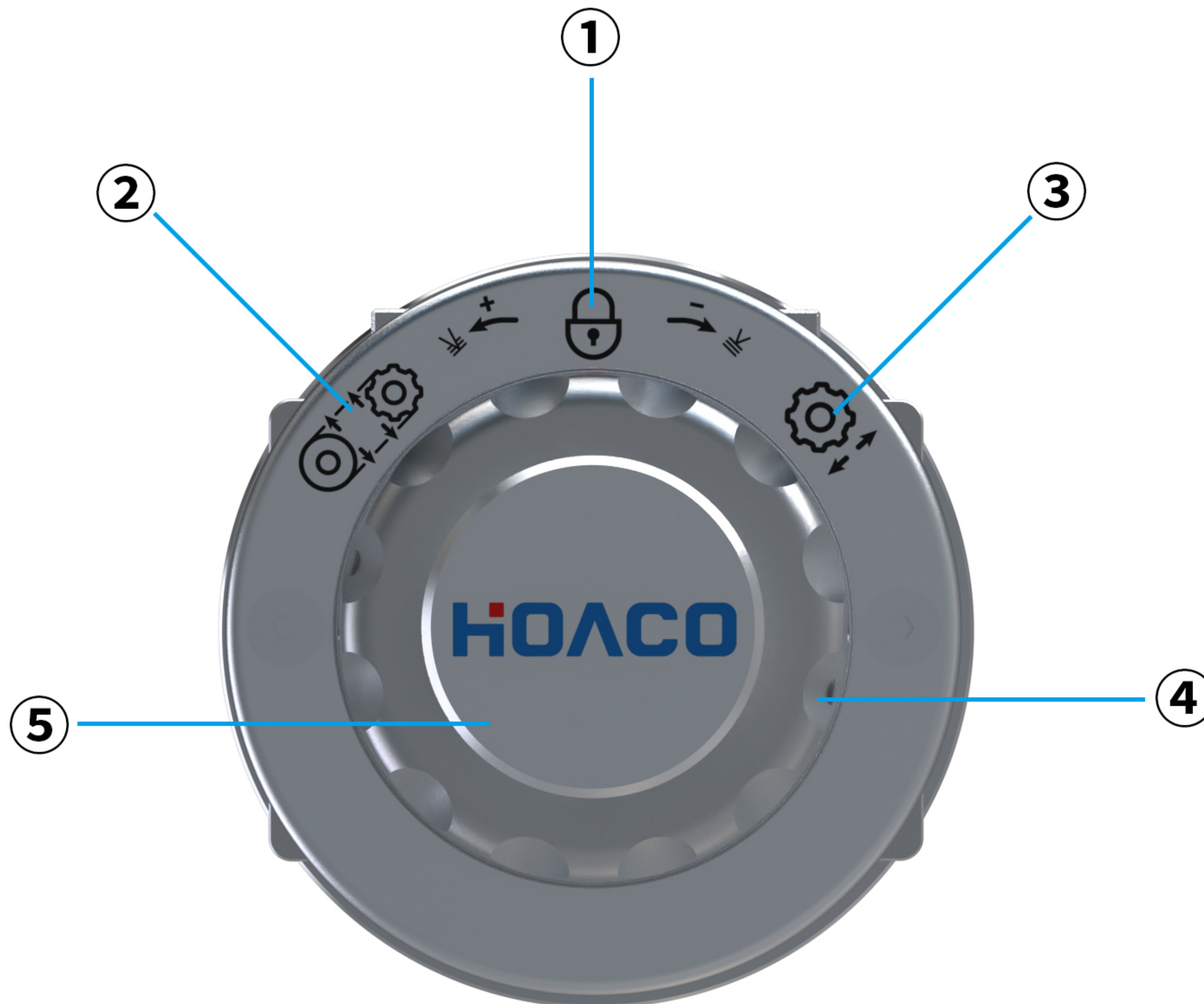

6.Height Adjustment

6.1.Adjustment Instructions



- | | | |
|---------------|------------------------|------------------------|
| ① Lock | ② Dual Side Adjustment | ③ Gear Side Adjustment |
| ④ Height Knob | ⑤ Selector Knob | |

6.2.Height Adjustment Operation

- 6.2.1. Turn the selector knob counterclockwise to  the "dual side" position. Rotate the height knob counterclockwise to move both sides of the anvil upward simultaneously. Rotate the height knob clockwise to move both sides of the anvil downward simultaneously.
- 6.2.2. Turn the selector knob clockwise to  the "gear side" position. Rotate the height knob counterclockwise to move the gear side of the anvil upward. Rotate the height knob clockwise to move the gear side of the anvil downward.
- 6.2.3 Turn the selector knob to the middle  "lock" position to lock the selector knob and the internal mechanism, ensuring the anvil position remains fixed after adjustment and preventing accidental operation during machine running.

7.Scale Indication And Adjustment Accuracy

The FlexiAnvil is equipped with two main scale windows, corresponding to the gear side and the knob side, displaying the current adjustment position of each side in real time.

With a built-in high-precision, large-ratio reducer, the minimum adjustment increment of the knob reaches 0.0005 mm, enabling finer and more precise control of the gap between the anvil and the die blade.

The FlexiAnvil is equipped with a height limit function, which restricts the maximum adjustment travel of the anvil by means of a mechanical limit.

	<ul style="list-style-type: none"> ● Adjustment unit: 0.001 mm; Minimum division: 0.001 mm. ● When the scale indicates "0", the top surface of the anvil is level with the top of support ring – this is the zero reference position of the anvil. ● When the scale shows a "+" value, the anvil moves upward, its top surface is higher than the support ring, the gap between the anvil and the upper rotary die decreases, and the blade cuts deeper. ● When the scale shows a "-" value, the anvil moves downward, its top surface is lower than the support rings, the gap increases, and the blade cuts shallower.
	<ul style="list-style-type: none"> ● Rotate the height knob counterclockwise to move the roller upward. The anvil top rises above the support rings, reducing the gap to the upper rotary die, and the blade cuts deeper. ● Rotate the height knob clockwise to move the roller downward. The anvil top lowers below the support rings, increasing the gap to the upper rotary die, and the blade cuts shallower.
	<ul style="list-style-type: none"> ● Instructions for Height Limit Adjustment <ol style="list-style-type: none"> 1. Loosen the two locking screws J1 and J2; 2. Rotate the adjustment dial through the two holes on the dial to set the height limit position of the anvil; 3. After adjustment, tighten the two locking screws. <p>Note:</p> <ol style="list-style-type: none"> ① The scale on the height limit dial is for reference only and serves as a rough indication of the anvil position. ② When the anvil heights on both sides are not equal, the scale value corresponds to the gear side.

Recommended Use of the FlexiAnvil

Before pressing the rotary die, adjust the height of dual side of the anvil to create a 0.02 mm gap between the anvil and the die blade. After placing the material, further adjust the anvil until acceptable cutting results are achieved.

8.Maintenance

8.1.Lubrication:

The FlexiAnvil is pre-filled with grease and does not require additional lubrication.

8.2.Cleaning

8.2.1.To prevent grease or lubricant leakage, do not spray solvents or perform immersion cleaning in the gap between the anvil and support rings. Only use a cloth moistened with a dedicated rust-preventive cleaning agent to wipe off dirt.

8.2.2.To ensure optimal die-cutting performance, keep the anvil surface, support rings, and adjustment components free of contaminants such as ink residues or adhesive. Any dirt – especially on the roller and support rings – must be removed immediately. Do not use sharp or hard tools such as scrapers or screwdrivers for cleaning.